

Thank you for purchasing FATEK HMI. Before installing or operating the unit, please read this installation guide carefully to ensure correct use.

## 1. Safety Precautions (Read these precautions before use.)

### 1.1 General

- Unpack and check the delivery for transportation damage. If any damage or deformation is found, please notify the supplier.
- The supplier is not responsible for the disassembled, altered or modified device.
- Never allow fluid or any conductive particles to enter into the HMI. Otherwise, it may damage the HMI, cause fire or malfunction.
- Only qualified personnel may install the HMI, perform maintenance and inspection.
- The liquid crystal inside the LCD panel is a hazardous substance. If the panel is damaged, avoid contact with the leaked liquid crystal. If the liquid crystal spills on clothing or skin, use soap and wash off thoroughly. In case of eye contact the liquid, hold the eye open, flush with plenty water and get medical attention as soon as possible.
- Do not touch any terminals while the power is on. Otherwise, it may cause injury due to electrical shock.
- Disconnect the power supply before installing the HMI, do wiring operation, perform maintenance or inspection. Otherwise, it may cause damage or electrical shock.

### 1.2 Installation

- The installation may be carried out by qualified personnel only.
- Install the HMI according to the installation procedures.
- Check the power source voltage is within the specified range and the polarity is correct before connecting the HMI
- Keep signal and power supply cables away from high-voltage, large-current carrying cables.



## Caution

Make sure the HMI is properly grounded to prevent electrical shock, fire or malfunction.

### Recommended

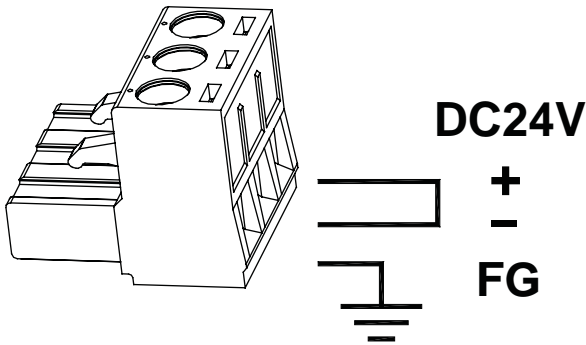

### Prohibited

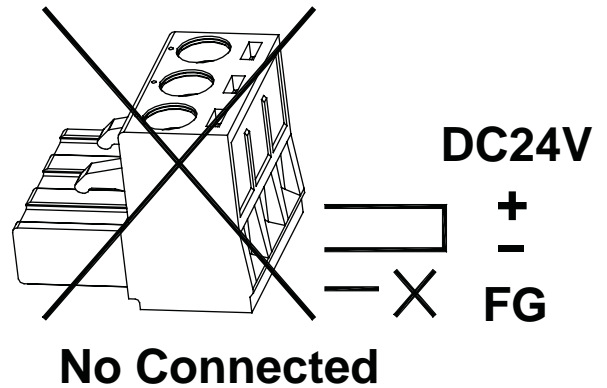

- HMI unit and other equipment should have the same electrical grounding (reference voltage level), otherwise communication errors may occur.

### GOOD

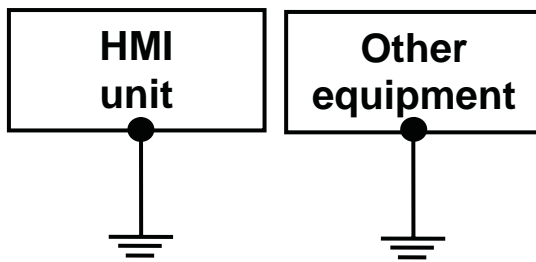

### BAD

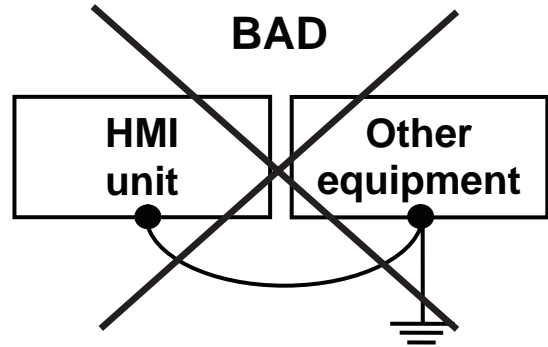

## 1.3 Operation

- Do not use sharp objects or excessive force to press the touch screen. This may damage the touch screen. HMSP102 screen protector can be applied to the HMI screen to protect it from damage, for ordering information, please contact our sales department.
- Do not use the output signal of the device as any safety function or system emergency stop. It may result in personal injury or equipment damage if a malfunction of the touch occurs.

## 1.4 Maintenance and Service

- The agreed guarantee applies.
- Only qualified personnel should make repairs and perform maintenance.
- Disconnect the device from the power supply before carrying out cleaning or maintenance.
- Clean the front panel with a soft cloth and mild detergent.
- Please use original replacement spare parts or accessories.

## 2. Part Names and Dimensions

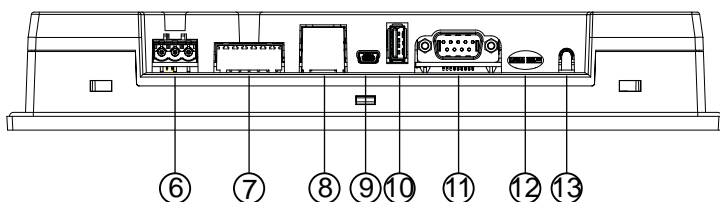
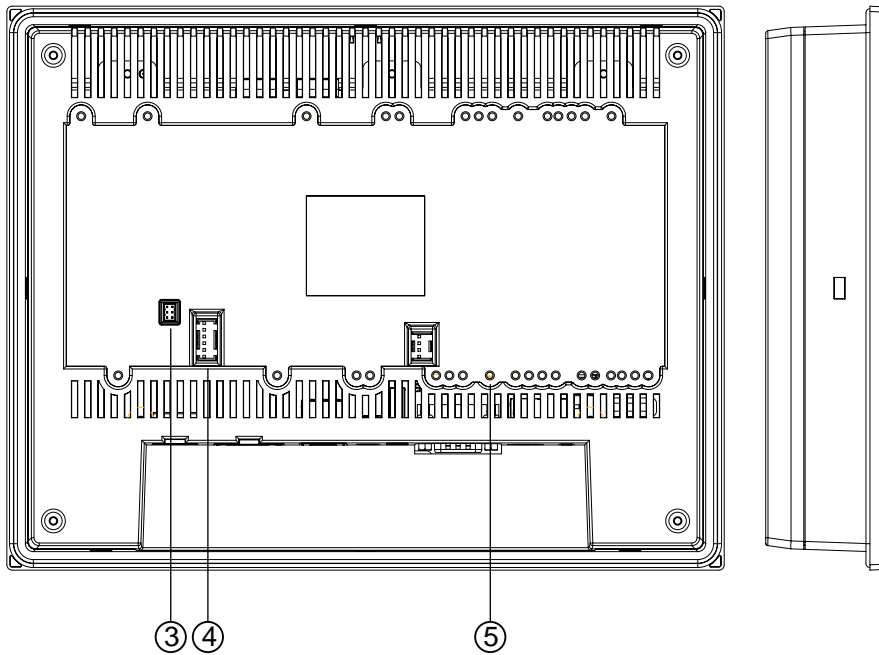
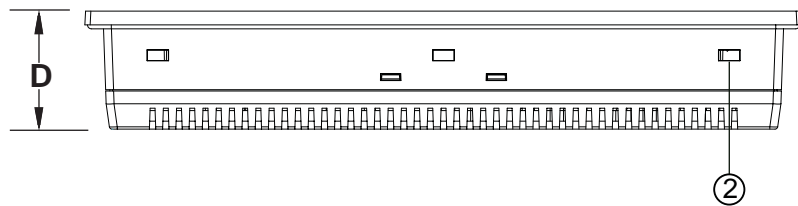
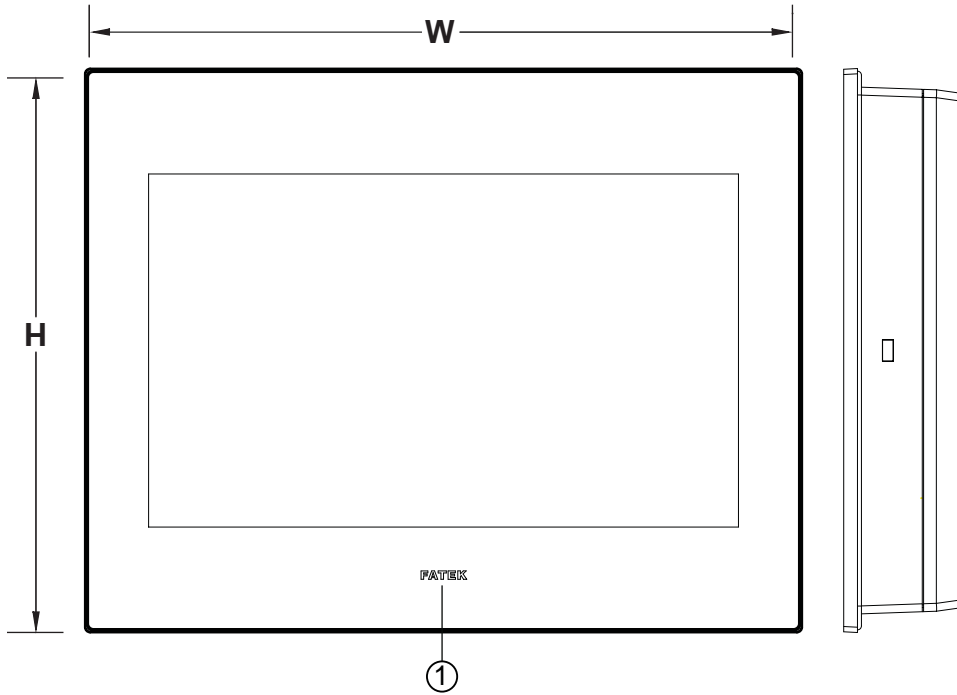

①	Power Indicator Light
②	Mounting Hole
③	HB1 PLC Connector
④	COM3/COM4 Termination Switch
⑤	HB1 PLC Screw Hole
⑥	Power Connector
⑦	COM3/COM4: Pluggable Terminal Block
⑧	Ethernet RJ45 Connector (for N/N1 model)
⑨	Mini USB Connector
⑩	USB Connector
⑪	COM1: DB-9 Male Connector
⑫	Micro-SD Card Slot (for N1 model)
⑬	Audio Phone Jack (for N1 model)

W	271.5 mm
H	213.5 mm
D	44.6 mm

# 3. Specifications

Model		P5102S	P5102N	P5102N1
UL 61010-1 Technical Consideration	Type of item tested	Control		
	Product Description	Operator Panel		
	Connections to mains supply	Permanent		
	Overvoltage category	II		
	Pollution degree	2		
	Means of Protection	Class III		
	Environmental conditions	Operating Temp. 0~50°C Storage Temp. -20~60°C		
	For use in wet locations	No		
	Equipment mobility	Built in		
	Operating conditions	Continuous		
	Overall size	271.5 x 213.5 x 44.6 (mm)		
	Weight	1340 (g)	1360 (g)	1380 (g)
	Marked degree of protection	Front panel: IP65 / Rear Case: IP20 to IEC 60529 Type 1 to UL 50E		
	Equipment classification	Industrial, Professional, Commercial		
	Equipment class	Class III		
Equipment type	Permanently connected, Fixed			
I/O Port	Serial 1	Connector: D-Sub 9-Pin COM1: RS-232 (TXD, RXD, RTS, CTS) Connector: Pluggable Terminal Block COM3: RS-422/485 (Isolation) COM4: RS-485 (Isolation)		
	Serial 2			
	LAN	---	10M/100M	10M/100M
	USB	USB2.0 Type-A (Host)x1 USB2.0 Type mini-B (Device)x1		
	Micro SD	---	---	Yes
	Audio	---	---	Yes
	PLC Extension	HB1 main units + B1 extension modules		
	Termination Switch	Yes (For RS-422/485)		
Power	Power Input	24VDC±20% (Isolated Power)		
	Consumption	420mA@24VDC		
	Insulation	50MΩ at 500VDC		
Environment	Relative Humidity	10%~90%@ 40°C (non-condensing)		
	Withstand Voltage	AC500V/20mA/1 Min. (between charger & FG terminals)		
	Vibration	5 to 9Hz Half-amplitude: 3.5mm 9 to 150 Hz Constant acceleration: 19.6m/s <sup>2</sup> (2G) 3 directions of X, Y, Z: 10times (IEC61131-2 complaints)		
	Noise Suppression	1000Vp-p, width 1us, rising time 1ns		
	Grounding Resistance	Below 100Ω		
Dimension	Cut-out	259.5 x 201.5 (mm)		

## 4. Unpacking the Unit

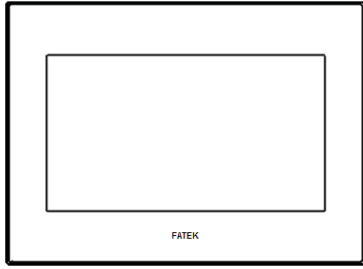

FATEK HMI x1

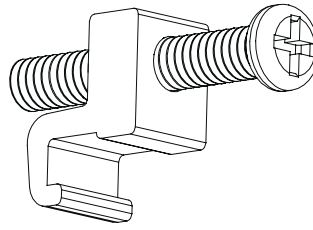

Hook and Screw x7

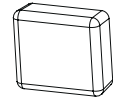

FATEK PLC  
Connector Rubber  
Cover x1



A4 Double-sided Installation Guide x1

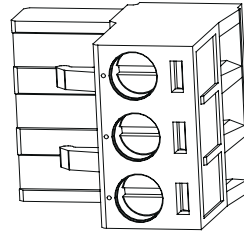

Power Connector x1

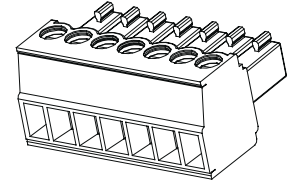

Pluggable Terminal  
Block x1

## 5. Installation Procedures

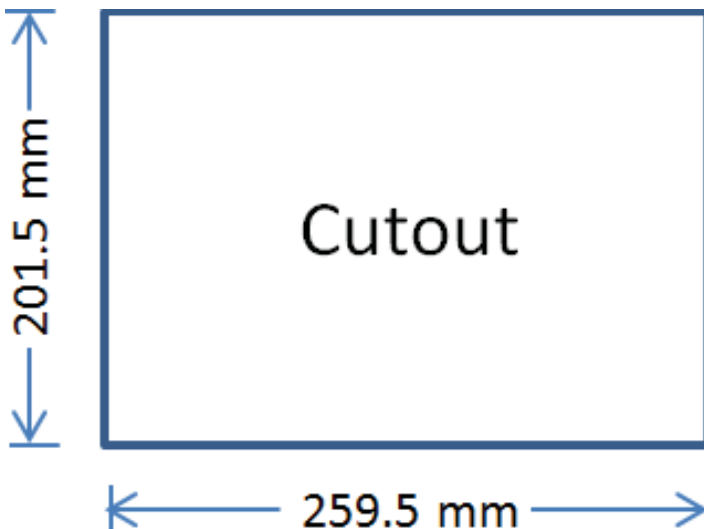
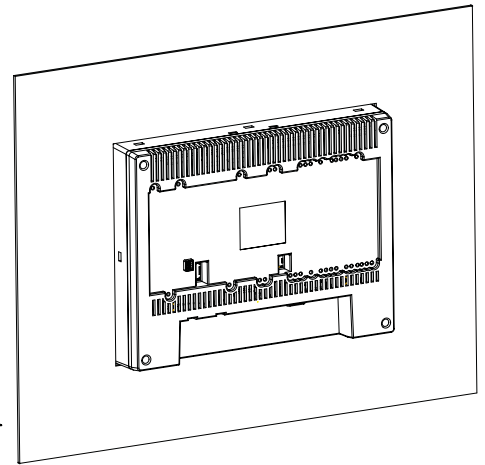
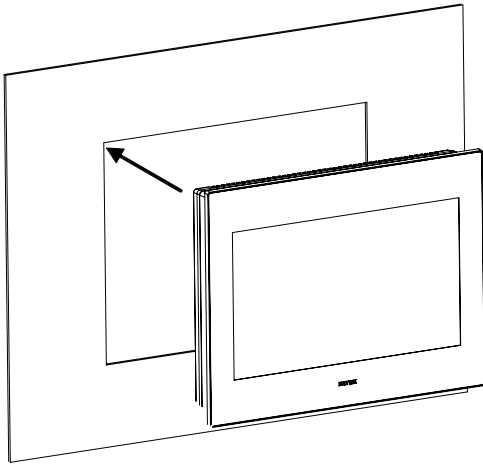

- Push the HMI into the cutout until the waterproof ring contacts the plate.
- Insert a hook into each mounting hole on the HMI, and then tighten the screws evenly with a moderate torque.
- Failure to tighten the screws may cause the HMI to fall, malfunction or short-circuit. Excessive tightening may cause deformation. The necessary torque is about 0.16N·m.

# 6. Power Connection

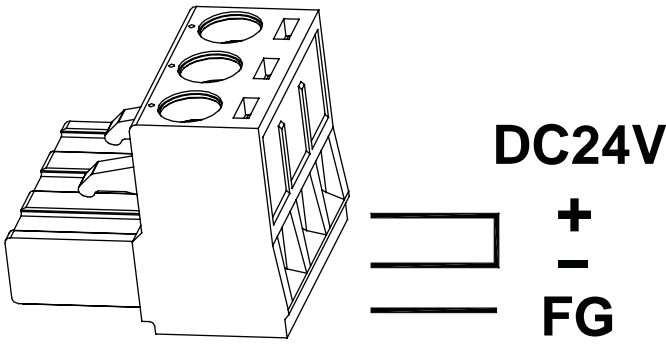

- Be sure to connect the ground FG terminal to a class-3 ground (Ground resistance should not exceed 100Ω). Try to make the ground wire as short as possible.
- Use 28 – 12 AWG (0.5 – 1.5 mm<sup>2</sup>) wire for the power connections.

# 7. Termination Switch

- P5102S/N/N1 HMI has a built-in termination resistor switch. To enable or disable the termination resistor please follow the configuration shown in the table below. The termination switch is for COM3 [RS-422 / RS-485] and COM4 [RS-485].
- Configuration of Termination Resistor Switch.

Termination Resistor						
No.	COM3 [RS-422]		COM3 [RS-485]		COM4 [RS-485]	
	Enable	Disable	Enable	Disable	Enable	Disable
1	<b>ON</b>	OFF	OFF	OFF	OFF	OFF
2	<b>ON</b>	OFF	OFF	OFF	OFF	OFF
3	<b>ON</b>	OFF	<b>ON</b>	OFF	OFF	OFF
4	<b>ON</b>	OFF	<b>ON</b>	OFF	OFF	OFF
5	OFF	OFF	OFF	OFF	<b>ON</b>	OFF
6	OFF	OFF	OFF	OFF	<b>ON</b>	OFF

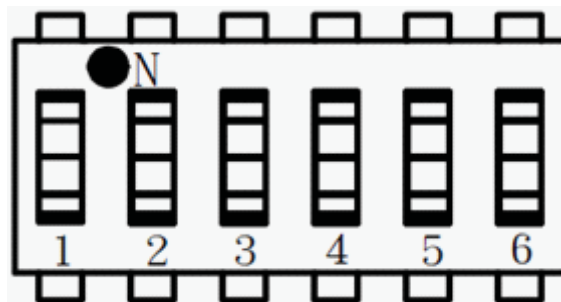

## 8. Pin-out of COM Ports

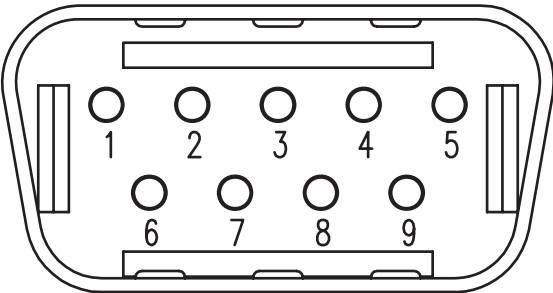
DB-9 Male Connector	
	
PIN#	COM1 [RS-232]
1	NC <sup>*1</sup>
2	RX
3	TX
4	NC
5	GND
6	NC
7	RTS
8	CTS
9	NC

\*1 NC: No Connection

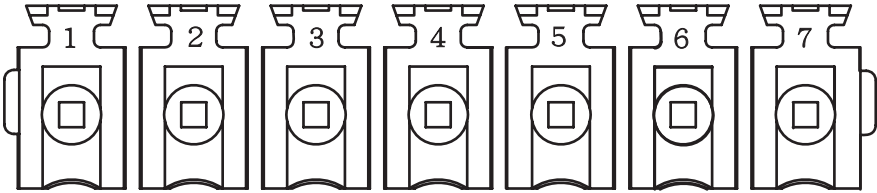
Pluggable Terminal Block			
			
PIN#	COM3 [RS-422]	COM3 [RS-485]	COM4 [RS-485]
1	NC	NC	DATA+
2	NC	NC	DATA-
3	ISO_GND	ISO_GND	ISO_GND
4	RX+	NC	NC
5	RX-	NC	NC
6	TX+	DATA+	NC
7	TX-	DATA-	NC

## 9. PLC Extension Tips

- For compact size and saving space, using FATEK HB1 main units + B1 extension modules is recommended.
- The rubber cover of the PLC connector can be taken off and placed into the termination switch slot.

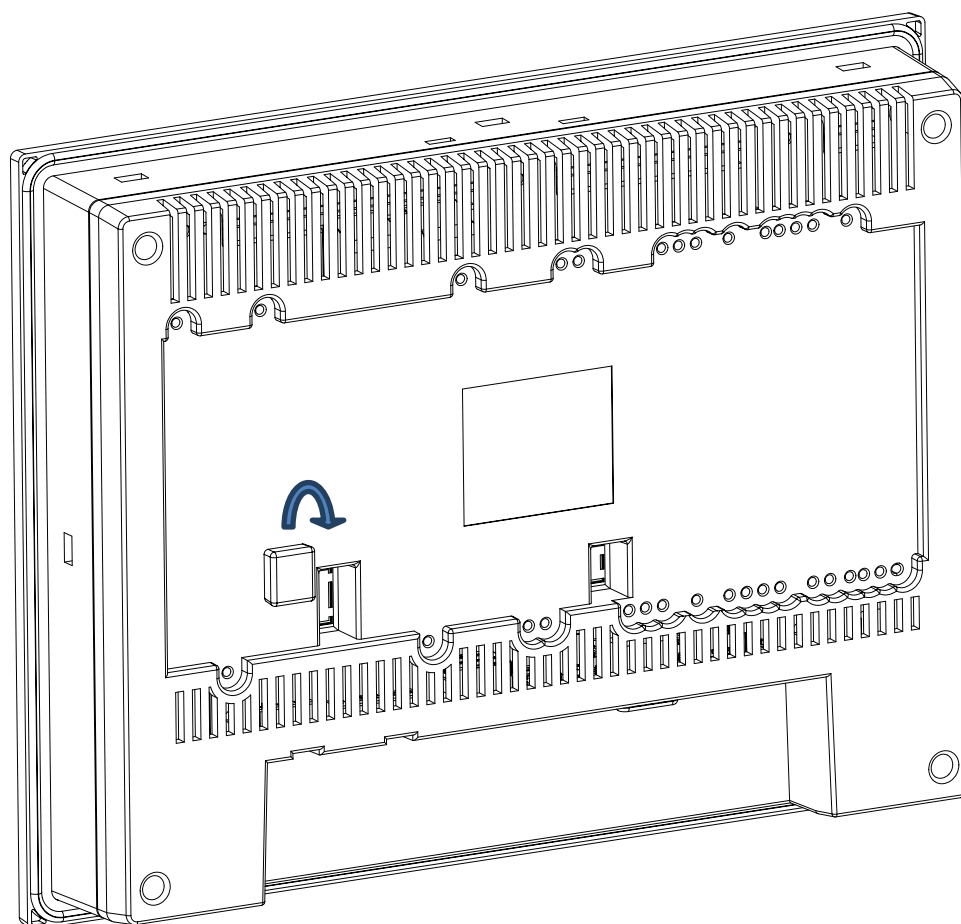

: